

QSMOTOR Motor Manual

Basic Info

Motor wires: three phase lines and two hall

1. Three phase lines

Yellow wire: U/1/A

Green wire: V/2/B

Blue wire: W/3/C

2. One hall set of V1 type Motor.

Two hall sets of QS motor (V2 & V3 type): you could choose one hall to use, the other one is for spare, in case of inconvenient of maintenance in abroad.

The diagram of two halls for your reference.

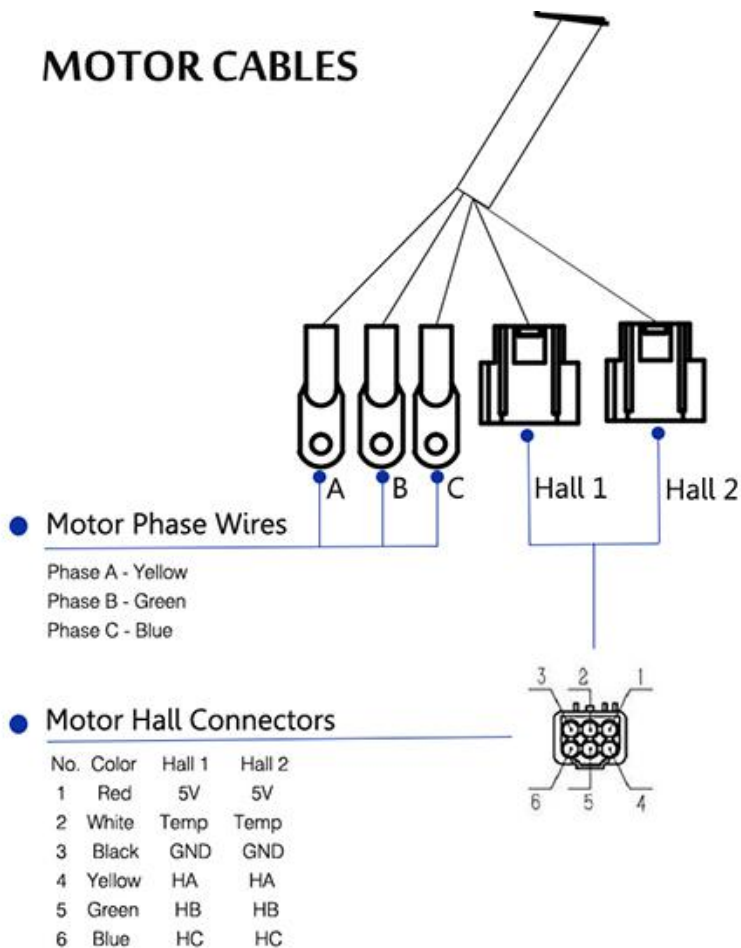

For QS Motor Different Version:

V1 with one Hall,

V2, V3, V4 with two Halls. (one hall for spare)

Note: power less than 1kw without temp sensor.

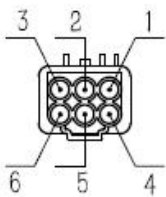
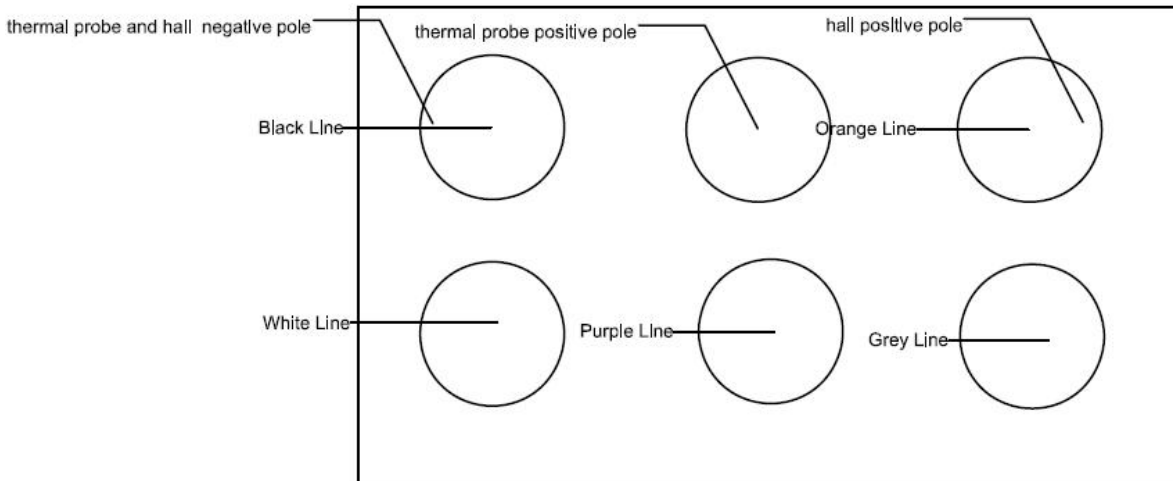
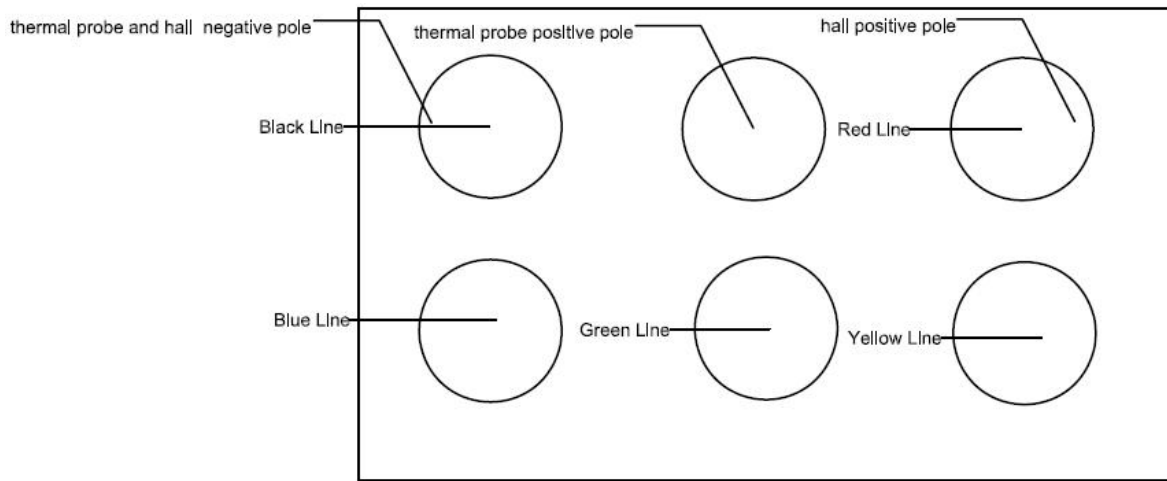
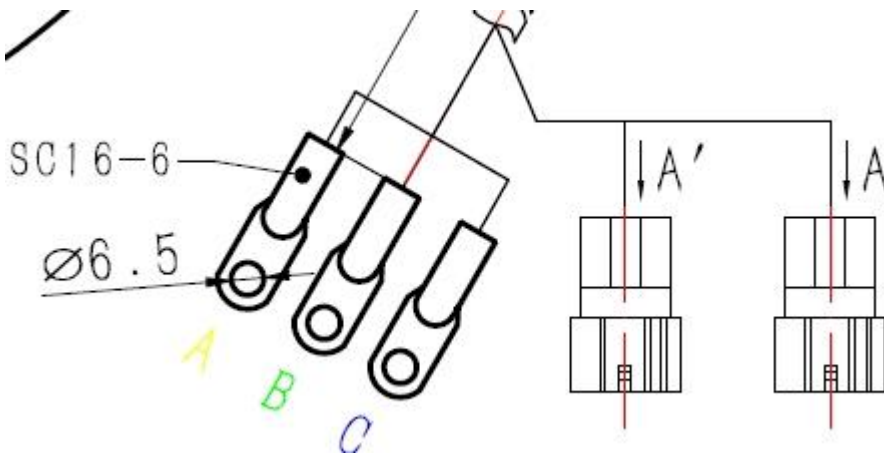

A、A' 位置定义			
位置	A颜色	A' 颜色	定义
1	红(red)	橙(orange)	VCC5V
2	透明transparent	透明transparent	KTY83-122
3	黑(black)	黑(black)	GND
4	黄(yellow)	灰(gray)	HA
5	绿(green)	紫(purple)	HB
6	蓝(blue)	白(white)	HC

P.S.: Hall Sensor is sensitivity, it might be brake down by static electricity over 5V.

The static electricity in our hand is far more than 5V.

Taizhou Quanshun Electric Drive Technology Co., Ltd. powered by SiAECOSYS

Please don't touch the metal part when modifying. If you have to, please wear wrist strap.

Motor Poles

The motor mark with "WP" is V3/V4 Type, if without "WP", then the motor is V2 Type or V1 type.

Pole Pairs of V3/V4 motor: 16pairs

Pole Pairs of V2/V1 205 motor: 23pairs

Pole Pairs of V1.1/V1.3/V1.4 260 motor: 24pairs

Pole Pairs of V2/V1 273 motor: 28pairs

Phase Angle of motor: 120°

Thermistor

To check Temp/thermal Sensor by multimeter, set the multimeter to ohm test.

Connect the red probe with the transparent wire of hall sensor. In the same way , connect the black probe with the black wire of Hall sensor.

Generally, it's 1kΩ for KTY83/122 at 25°C (data below).

<https://www.dropbox.com/s/7mdygm9bbwxtv63/Thermistor%20KTY83-122%20%20Data.pdf?dl=0>

Installation

Regarding QS138 V3 IPM motor, the vent-pipe should be downwards, or there is oil leak risk.

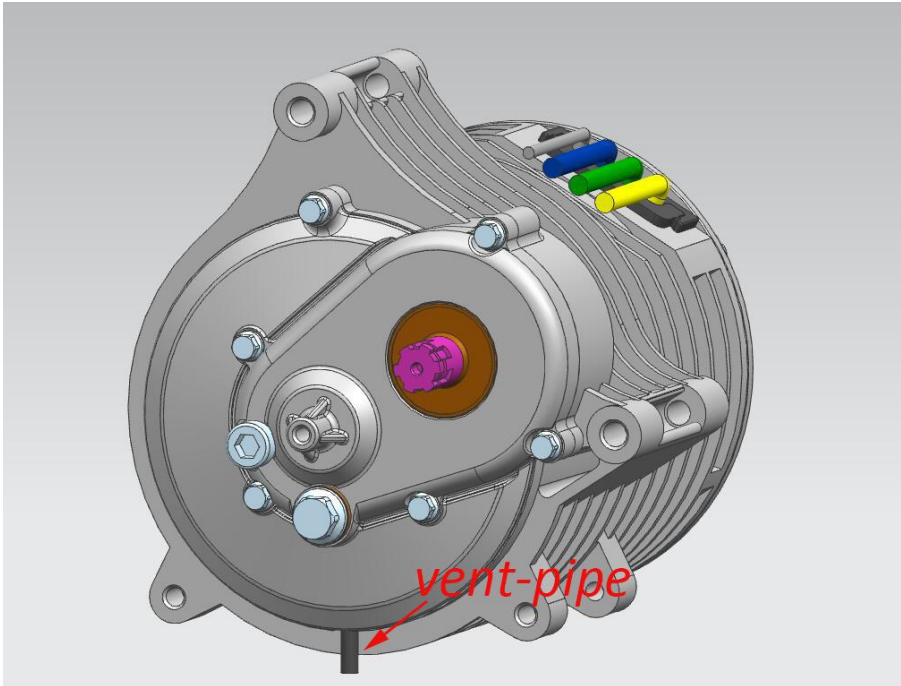

Tips

Waterproof

For hub motor, waterproof grade is IP65.

For 120 2000W IPM motor and 138 3000W V3 IPM motor, it's IP67.

For 138 3000W V1 / V2 IPM motor, it's IP66.

If there is high waterproof request for e-scooter (like below), we suggest to choose IP67 IPM motors.



For Hub motor, it could work in some wading area within it's tire radius, not cover axle hole.

For example, 120/70-12 tire (radius 23cm), it could be IP67 within 20cm.

For some wading area over 20cm, there is risk.

For short time/distance, riding through is generally ok, as motor keep heat.

For long time/distance, push e-scooter all the time(keep motor cool) or riding e-scooter all the time (keep heat) is generally ok, the worst-case is running halfway and stop work, the water will get inside motor during breath.

For soaking in water in long time, it is not ok.

Mounting tips against rust

Generally, controller mount under seat inside of plastic cover, which protect from water and mud. Motor will breathe during working and non-working because of Expansion and Contraction. Our hub motor is IP65, water might come inside from phase wire outlet (in red arrows).



Low mounting position, lack of protection

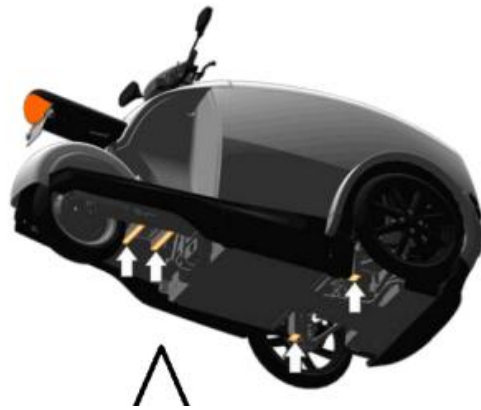

Water get inside after cutting phase wire shield



So don't mount the motor and controller in low position, and shorter phase wire is not suggested (might for quick release purpose).

In some area like Vietnam, the motor might wade into the water in rainy season.



Make sure the wire going up is very important, and far away from water.

Sometimes, water might get inside through bolt gap, please also pay attention on this to protect motor phase wires.



Moreover, the motor phase wire outlet should be adown if possible like below.



Btw., someone might glue filling of motor phase wire outlet for better waterproof. As motor need breath during heat and dissipation heat (via phase wire), there will be way for breathing, so the glue filling is not suggest.

For motor hall signal to speedometer

Some customer prefer to take hall speedometer signal from one of motor hall wire (yellow/green/blue), as some controller don't have extra hall signal wires.

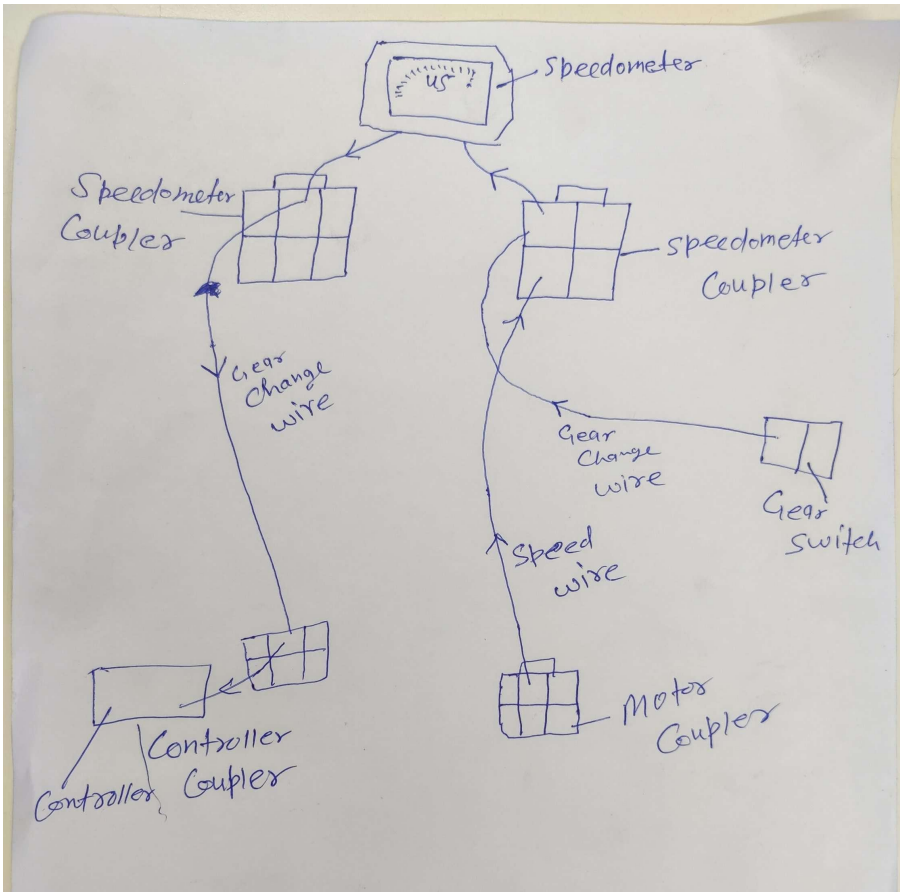

It could work at the beginning, but during raining season, the controller MCU and motor hall might get damaged because of short circuit.

Please pay attention on this, the hall speedometer signal could be set in VOTOL controller.

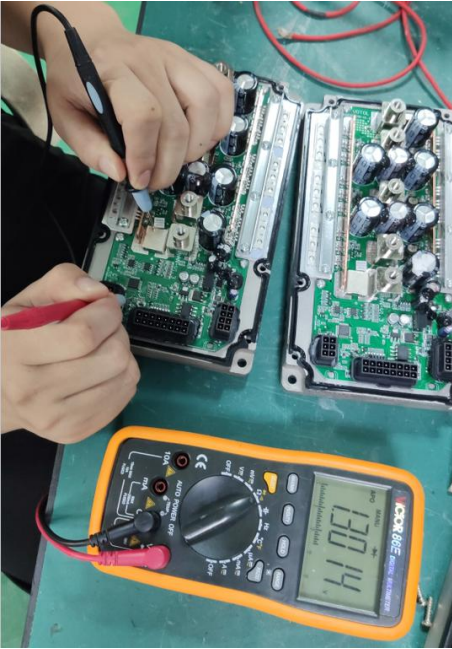

Temp rise attention

Temp rise might cause overheat issue, which burn motor or controller.

During prototype testing, especially for some hill area (like some hill are in Korea/Iran/Italy), please pay attention on this, the temp could be monitored by controller.

For VOTOL controller, there is motor temp and controller temp on display page.
Suggestion (Setting of Controller)

VOTOL-EM-V3 Software Debugging

PAGE1 PAGE2 PAGE3 Display Port Settings

RPM: 0

Voltage: 0

Cuttent: 0

Controller Status: IDLE

Fault Code: IDLE

Fault display:

- Hall Fault
- Brake
- Motor hall
- Undervoltage
- Overvoltage
- Overcurrent
- Controller Failure
- Out of contro
- Overheating

Controller temp(?):

External temp(?):

Temp coefficient

Gears:

- L M
- H S

• R • P

• Brake • ANTI THEET

• SIDE • Regen

STAND

success_count: 0

error_count: 0

import prarm save prarm

connect param write

PORT: OPEN

status: research

Analog vehicle instrument display

- 1.Speed: display the actual speed of the motor
- 2.Voltage: display the actual output voltage of power supply and battery
- 3.Current: display the actual output current of power supply and battery
4. Fault display: display vehicle fault
- 5.Gear display: display the current gear of the vehicle
- 6.Function display: display the current functions of the vehicle
- 7.Controller temperature: display controller chip temperature
- 8.External temperature: display motor temperature
- 9.Temperature coefficient value: display controller hardware coefficient

For V1 motor, when it's 120 °C , the controller shut down. When it drop down to 100°C , the controller work again.

For V2/V3/V4 motors,

When it's 130 °C inside of motor (in 30s), the current should be limited 50%.

When it's 145 °C, the controller shut down. When it drop down to 110 °C, the controller work again.

If motor get overheat easily or even burnt without overheat protection, please make more clear request about temp rise request (climbing angle @ speed @ weight @ duration), and double check with sales. Our engineer could make review and model selection, doing temp rise test accordingly. There might need more powerful motors, and some customer prefer to mark higher power rated motor to less power (e.g. 2000W motor, mark 1500W).

Pothole attention

Please driving slowly when passing through pothole, to avoid motor wheel bend transformation.



Controllers & other kits

For controller and other kits, please contact with sales for latest manuals.

Kelly KBLs sine wave controller (the files as same as KEB series except Software)

1. how to connect Kelly controller to our motor

The connection way of motor and controller—— three phase and hall connection.

three phase lines

hall (plug to plug)

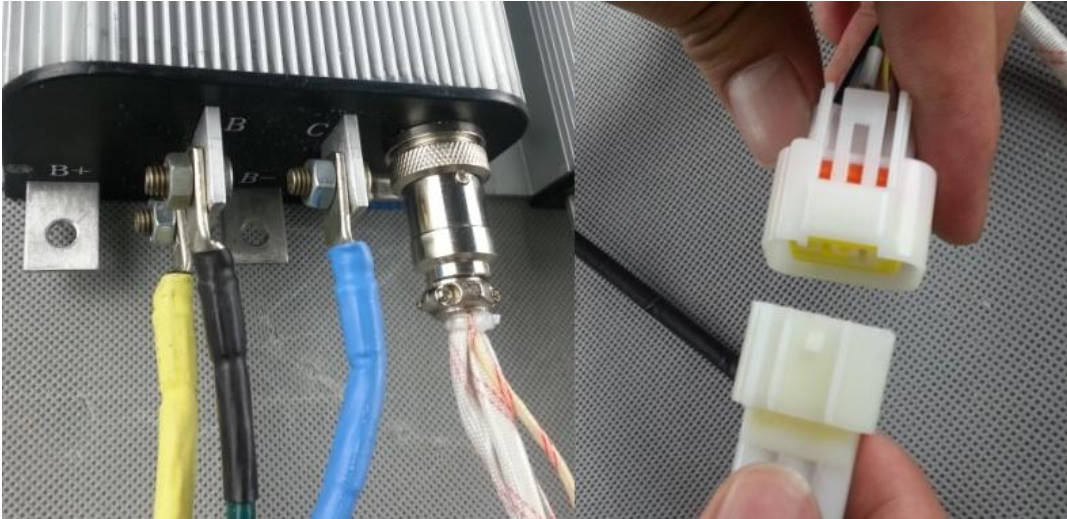

2. Kelly Controller user manual

<http://kellycontroller.com/mot/downloads/KellyKEBUserManual.pdf>

3. KBLs Controller Software(Sine Wave Controller)

Android System(phone):

<https://www.dropbox.com/s/a7ivds8rI9hpkzc/Software%28phone%29ACAduserEnglish.apk?dl=0>

P.S.: for phone using, you should buy one more USB cable to connect controller with your phone.



Computer software:

For XP:

<https://www.dropbox.com/s/0a8xs9mng1e4wpd/WinXP%20sine%20wave%20controller%20software.rar?dl=0>

For Windows 7:

<https://www.dropbox.com/s/8v5v3mrxbybIn4a/win7%20sine%20wave%20controller%20software.rar?dl=0>

4. Connect Kelly Controller to a Computer

Taizhou Quanshun Electric Drive Technology Co., Ltd. powered by SiAECOSYS

<http://kellycontroller.com/ConnectHelp.php>

5. How to adjust parameters of controller

<http://kellycontroller.com/KEBhelp.php>

6. Wiring Diagram of Controller

<http://kellycontroller.com/mot/downloads/KEB.zip>

Kelly KEB controller

1. Kelly Controller user manual

<http://kellycontroller.com/mot/downloads/KellyKEBUserManual.pdf>

2. Controller Software

<http://kellycontroller.com/mot/downloads/Kelly%20KBL%20and%20KEB%20User%20Program%20Release%20Setup%20v4.1.zip>

3. Connect Kelly Controller to a Computer

<http://kellycontroller.com/ConnectHelp.php>

4. How to adjust parameters of controller

<http://kellycontroller.com/KEBhelp.php>

5. Wiring Diagram of Controller

<http://kellycontroller.com/mot/downloads/KEB.zip>

Kelly KBL controller

1. User manual

<http://kellycontroller.com/mot/downloads/KellyKBLUserManual.pdf>

2. Controller Software

<http://kellycontroller.com/mot/downloads/Kelly%20KBL%20and%20KEB%20User%20Program%20Release%20Setup%20v4.1.zip>

3. Connect Kelly Controller to a Computer

<http://kellycontroller.com/ConnectHelp.php>

4. How to adjust parameters of controller

<http://kellycontroller.com/KBLHelp.php>

5. For more information

<http://kellycontroller.com/support.php>

6. **Notice:** If the controller comes with CAN protocol, For J1 cable, only need to use No. 10 and No.11CAN wires. J2 cable is normal using.

Kelly KBS controller

1. User manual

<http://kellycontroller.com/mot/downloads/KellyKBS-XUserManual.pdf>

2. Controller Software

<http://kellycontroller.com/mot/downloads/Kelly%20KBS%20User%20Configuration%20Program%20Setup%20v4.5.zip>

3. Connect Kelly Controller to a Computer

<http://kellycontroller.com/ConnectHelp.php>

4. How to adjust parameters of controller
<http://kellycontroller.com/KBS-Xhelp.php>

5. For more information
<http://kellycontroller.com/support.php>

6. **Notice:** If the KBS48101XY controller match with QS motor(from ours), the connect way should like below picture.

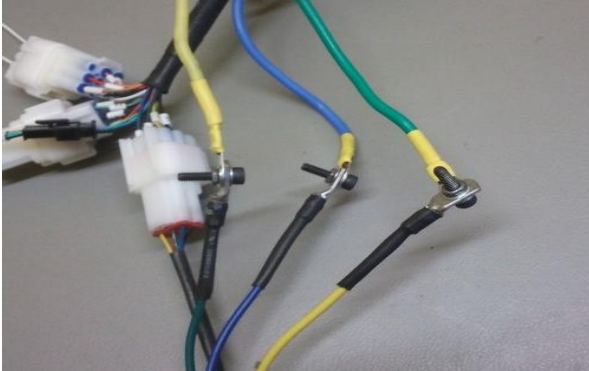

LBMC controller

1. how to connect LB controller to our motor

For V2 Type motor, normal connection.



For V3 motor, the **green and blue** color(phase wires and hall) should be exchanged.

Motor Brand	Type of Motor	No. Of Pole-Pairs	Phase-shift	Phase Configuration			Hall Configuration		
				Yell ow U	Green V	Blue W	yell ow	gree n	blue
Quanshun Tile-shaped Motor	10、12 inches、13 inches Tile-shaped (with X)	16	-120		blue	green		blue	green
	10、12inches、13inches Tile-shaped (without X)	20							

2. LB controller files.

<https://www.dropbox.com/sh/odch5hecaudwro7/AAD7sGrVCWifTxQMTNuWIA51a?dl=0>

Sabvoton Controller

Sabvoton controller files:

<https://www.dropbox.com/sh/yrhrr5ec59dfjl2/AAD8Vu1IKfkCtz0i6lpGBCuDa?dl=0>

Electric Speedometer X8-E

Programmable, suitable for 24v-120v

Speedometer X8-E files:

<https://www.dropbox.com/sh/d8i6if2zsjn3cgt/AABgoxR8keIJ9xH5nuLGGh6Sa?dl=0>

Electric Foot throttle

Foot Throttle Manual:

<https://www.dropbox.com/s/1alivjuy5js4pfs/Foot%20Throttle%20Manual.pdf?dl=0>

Warranty

After service for Sample and quantity production motor

1. Warranty period: one year and three months (since the date of manufacture) or after riding 15000KM.
2. Warranty coverage : ex-factory quality problem.
3. In order to ensure proper operation, please read the user's manual carefully in advance. If problems caused by the customer's wrong operation, we cannot cover the cost of maintenance. We could offer maintenance scheme if you need help.
4. Destructive testing is not included in the warranty scope. If you need repair to it, you have to cover all maintenance costs (include fro shipping cost, maintenance cost, customs clearance fee, customs duties and so on).

The damage caused by installation and bad working condition (for example: work eight hours at stretch every day, terrible road conditions, extreme condition e.g. over voltage using). In that case, we cannot provide warranty, but we can sell the spare parts for you to replace.

Definition of bad working condition

Over voltage using: For example, the rated speed of the 10inch 3000W hub motor 80km/h@72V condition. In order to speed up to 106km/h, someone would like to increase the voltage to 96V.

Bad road condition: Obvious uneven road, hills, muddy road, serious water-logging road etc.

Other situations: Motor continuous climbing /over load exceed 6 hours; motor driving above 80km for a long time etc..

5. There is no warranty committed in the following sequence.
 - A. The damage or issues caused by user who dis-assemble motor and change spare parts authorized.
 - B. The damage or problems caused by force majeure.
6. We supply 1% spare parts for bulk buying motor. E.g. hall sensor, hall plug and so on.
7. We will provide after sale service according to the motor serial number and anti-counterfeiting mark on the motor. So please keep them clearly, and offer the serial number and photo, video to us if any problem for motors.
8. The damage caused by violence of international transport (damaged condition refer to below points 1.2.3.4).
Before you sign the receive confirmation of express, please check the package box at first. If the packing box is broken, please keep on file with photo. Then open the carton and check the motor. If the motor was damaged, take photos of the detail and contact express members and us within 24 hours.
If the outer packing is intact, but the motor was damaged already, please follow the steps above.
We will provided a specific solution after received the feedback. Please mentioned that the valid feedback can't exceed 24 hours after you signed for confirmation. Or we may hard to afford the loss. We can offer a maintenance plan for you if you not on time.
9. Taizhou QS motor Co.,Ltd. reserve all the rights for the final explanation.
10. We will not bear the extra loss that caused by maintain motor. E.g. Time loss

Damaged situation:

1. Slight damage of the appearance (E.g. paint loss, scratch)

Painting if the damage not affect the performance of product.

2. Wheel rim out of the shape

2.1 Caused by customer: customer cover all the maintenance cost(include to and fro shipping cost, change wheel and magnet cost, customs clearance fee, customs duties and so on).

2.2 Caused by fragile package: please contact express members asap. After we get the feedback from express company, we can send the wheel rim with magnet to you for replacement, and video for guidance.

2.3 Caused by transportation: please also contact express members asap. After the express company confirm a compensate plan, we will send the wheel rim with magnet to you for change, and video for guidance.

3. Outlet wire damages of Axle

3.1 The rubber is broken, while the copper wire is fine (caused by transportation or customers), you can repair it by yourself
Taizhou Quanshun Electric Drive Technology Co., Ltd. powered by SiAECOSYS

with black tape.

3.2 The rubber and copper wires are both broken(especially for the single shaft motor). Please contact with express company immediately. We will supply a brand new stator for you to change according to degree of injury.

4. Hall damages

4.1 One hall is broken, you can use the spare hall (There are two halls for 1000W or above wattage). If both of them are broken, we will guide you how to change the hall.

5. Demagnetization and broken of magnets in hub motor

5.1 The magnets will be demagnetized after 2-3 years use. If the magnet steels are demagnetized in motor naturally, you could change them by yourself if you know how to do it. Also we could sell the wheel rim with magnets at favorable price for your replacement.

5.2 If you find the thickness of the some magnet steels are different from others in your hub motor, and check they are effect the motor driving, we will supply a new magnet steels for replacement.

5.3 If the magnet steels broken caused by begum, we will according to actual conditions, supply free new magnet steel for change. And also tell you the model of the glue, so that you can find it at local market.

6. Short Circuit of motor

6.1 We will guide you to find the reason. If you cannot test it, please send it back.(Before we find out the reason, the shipping cost and custom clearance fee need to paid by customer at first).

After checked by factory or by yourself(which followed with our guidance; if you checked it by yourself and didn't follow our suggestions, we are sorry that we cannot make maintenance later) , if the short circuit caused by quality problem, we will bear the shipping cost and maintenance cost in the warranty period. If it caused by use, the buyer need to bear the shipping cost, custom clearance and so on. We bear the maintenance cost only(repair only, not include parts replacement, for example: scraped stator cost.)

7. Internal rusted of motor

7.1 The internal rust is usually caused by the moisture or water of the motor. We can sell corresponding spare parts for you to change.

8. Winding burn

1.1 The winding burn usually caused by improper use. In that case, we can sell the stator for you to change.

After sales

Problems

How many failed motors are there?

Meanwhile, please advise the serial number of motor, make some description of the problem with some video and pictures, and take note to list as below.

Number	Serial Motor	Problem	Which hall sensor error
1	170220 5030xx	Hall sensor error (disassembled)	Blue NOK
2	170220 503030	Rotor cannot move, most likely due to corrosion	Cannot be tested due to locked motor
3

Analysis

Check problem, get more information to figure out the issue.

The main issue are hall sensor error, motor rust and burnt.

Hall sensor error

- There are 2 set hall sensor for V2/V3/V4 motor, change to another hall set if the motor run normally.
- Could you please measure the 3 hall sensor by multimeter, to check which hall sensor broken.

http://v.youku.com/v_show/id_XMzYzODM4Njc4MA==.html?spm=a2hzp.8244740.0.0

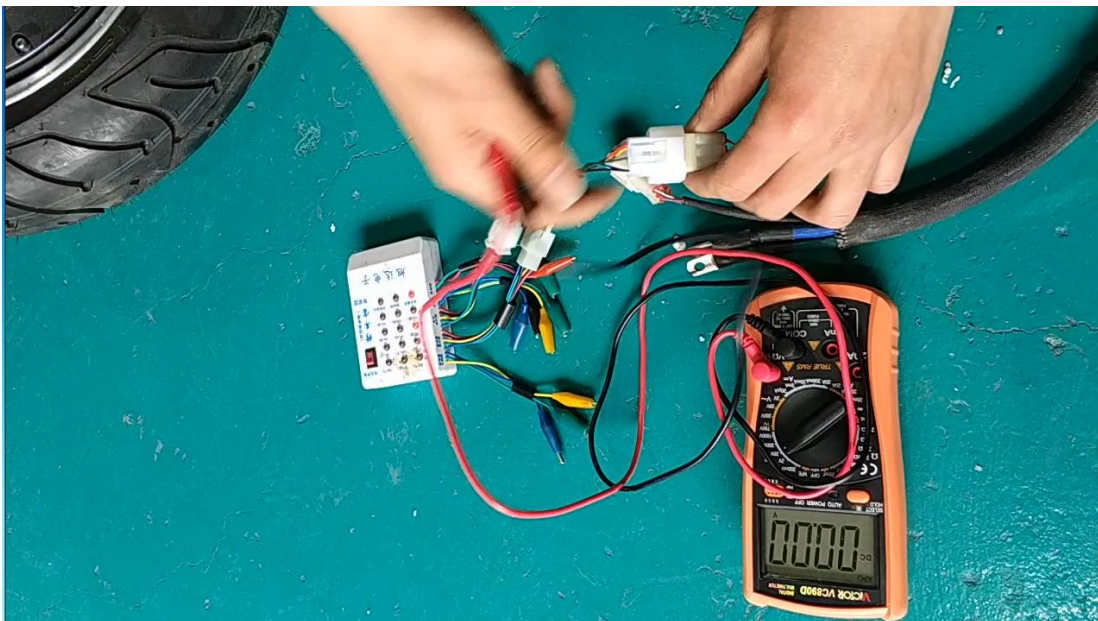

1 Electric Motor hall measurement:

1) **Instrument:** Multimeter , controller or 5V battery.

2) **Detailed schedule:**

- ①. Check the motor has connected with controller, and the electric lock/ignitor is on.

P:9.1

(if don

t connect with controllers, there should external connection with 5VDC battery) 。

②. Set the multimeter to voltage test(DC), As picture 9.3 shown below, connected Black probe with (COM), connected Red probe with (VΩHz) .

③. Connected the Red probe with the red wire of Hall. in the same way, connect the black probe with the black wire of Hall, in order to confirm the 5VDC is normal.

④. Connected the Red probe with Red wire of Hall (As picture 9.1 shown) , and connected Black Hall outgoing line (Yellow/Green/Blue, any one is okay), then turn the motor slowly by hand), the multimeter should change between 5V(actual 4.2V~4.8V) to 0V, it means the Hall sensor is work/okay. If the voltage keep 5V to 0V, the Hall sensor is not work

⑤. Use the same method to test the rest two Hall wires, in order to confirm weather the Hall sensor damage.

3). Precautions:

①. Once the motor connected with controller, we should confirm the controller power supply firstly. (The Red/Black line which Multimeter measured should be 5VDC).

②. External 5VDC power, positive pole connected with red wire of Hall, negative pole connected with Black wire of Hall, not allowed to access anti-Line.

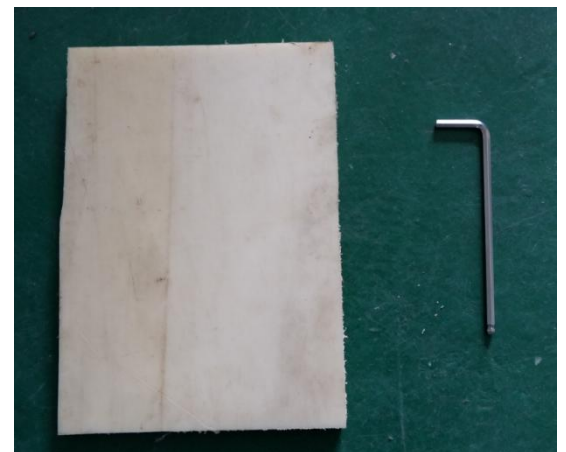
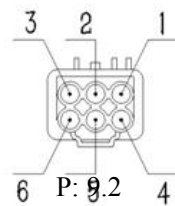

Phase wire short circuit and Rust

Mount the motor, get three phase wire separated, run the motor by hand, the motor could rotate normally without resistance, if not, there maybe phase wire short circuit or rust inside.

Motor electric leakage

Check insulation resistance between phase wire and side cover, by insulation resistance meter. If it's 0 Ohm, the motor is electric leakage. Refer to below picture.

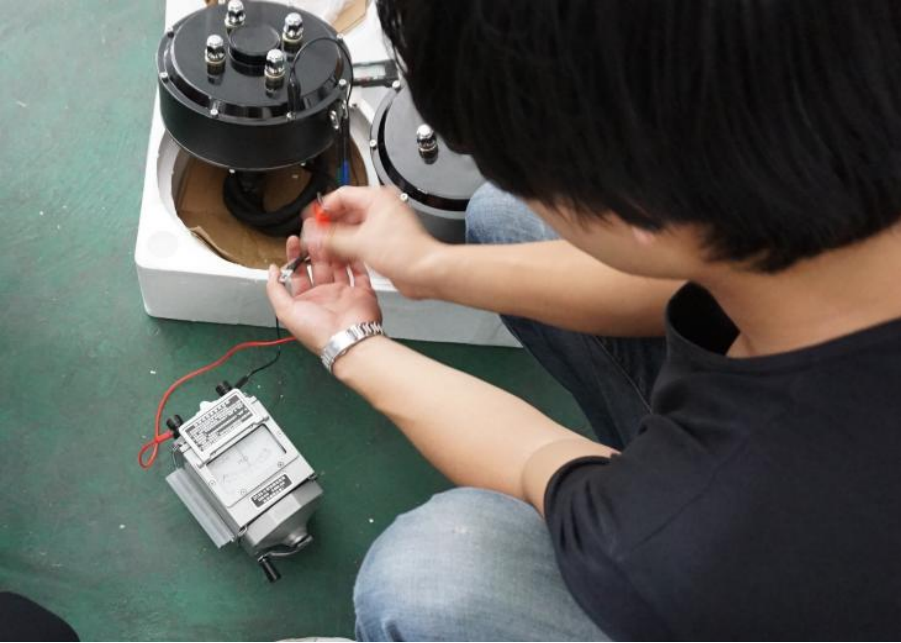

Repair

Disassemble the motor:

1). **Instrument** : 4mm Allen wrench, hammer, plastic board Or Nylon board. (As picture 9.4 show).

2). **Method:**

①. Use 4mm Allen wrench to disassemble the screws (Electric outlet side) one by one. P: 9.4

②. Grasp the Motor Hub with both hands, the motor shaft downwards (As picture 9.5 shown), then put your strength knocking the motor to rubber mat, in order to separate the Motor rim and Motor stator.

3) **Precautions:**

①. Disassembled all the Motor shaft accessories before disassembling the motor.

②. There has Strong magnetic steel paste on the Motor rotor, For safety, please don't reach your hand to Motor inside cover. (When the motor didn't completely disassembled down, then the motor stator was sucked back and hurt your hand).

③. Due to the enameled without shell protection after motor disassembled, it should be carefully placed, don't bump the coil.

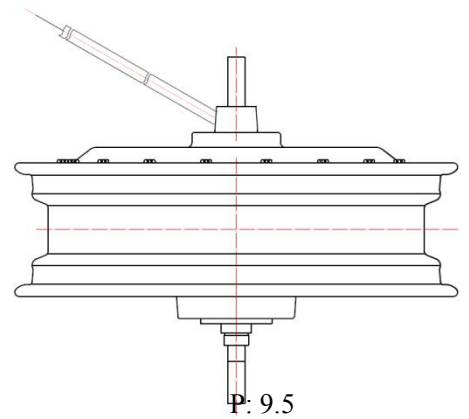

Replace the Hall sensor:

1). Instrument: Scissor, Electric iron, Multimeter.

2). Material: Hall sensor, Dry glue, Lashing band

3) Operation step:

①. Base on the Previous Page first line, according to Motor Hall sensor measuring method, confirm that Hall sensor damage.

②. Base on the Previous Page second item, according to Motor disassemble method, open the Motor

③. Use Scissor to clip the lashing brand and damage Hall. (Clip along the welding position of Hall line)

④. Use slotted screwdriver and blade to take out damage hall, clean up the Hall groove.

⑤. Put new Hall into the clean up Hall groove and immobilization by Dry glue.

⑥. Take down the casing of three Hall lines which clip from the damage Hall, and use Electric iron to boil out the welded connection which soldered before, then sheathe the 1x25mm Heat-Shrinkable T bush(RSBA) on the Hall line.

⑦. Use Electric iron to solder the three Hall Pin, welding Hall Foot with(As picture 9.6 showed) Hall line(Electric Iron best temperature is $380\pm 20^{\circ}\text{C}$), welding time of single Hall Foot should less than 1s; check the welded firm after welding, than use Heat-Shrinkable T bush(RSBA) to cover the Hall pin and weld, use Heat Gun to blow up the RSBA, finally wiped silica gel on the Hall foot for insulating treatment.

⑧. After the operation, arrange the Motor line, fastening by Lashing band.

⑨. Check the replace Hall work normal, method like Previous Page first line (Motor hall measurement).

4). Precautions:

①. Before Installing the Hall, it's necessary to get rid of static electricity.

②. When assemble the Hall, packing of the hall should install the neat, can't be incline and install out-position.

③. Before welding Hall, we should check the Electric iron, weather is electric leakage.

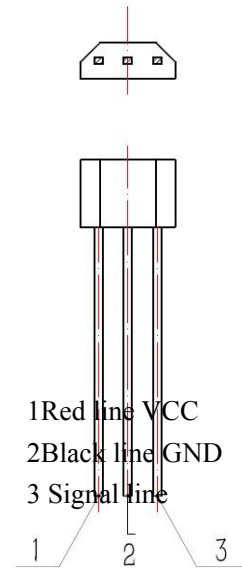

For Hall sensor error, hall sensor should be repaired by customers. QS should offer some instruction and videos, and essential accessories, e.g. hall sensor, glue for side covers.

As the glue is not available by express, it could be delivered by sea shipment or in luggage.

Refer to below link.

<https://youtu.be/VeL0FQom1CE?list=PL57T-PrhB7uakFfMk1bY3vTQ9gXQm2CLq>

QS Motor Electric In-Wheel Hub Motor Repairment-Change Hall Sensor

156,239次观看 · 2016年5月16日

621 101 分享 保存

QSMOTOR

QSMOTOR Technical Support After-Sale Service

QSMOTOR - 3 / 9

- 1 QS Motor 205 50H V3 Electric Bicycle Spoke Hub Motor... 2:55 QSMOTOR
- 2 QS Motor disassembly 135mm electric bike spoke... 4:48 QSMOTOR
- 3 QS Motor Electric In-Wheel Hub Motor Repairment... 21:02 QSMOTOR
- 4 QS Motor 205 50H V3 Electric Bike Spoke Hub Motor... 2:17 QSMOTOR
- 5 What QS Motor looks like after 1,5 years and 20.000 k... 3:59 QSMOTOR
- 6 Motor Disassembly Machine 0:21 QSMOTOR

Ebike Hub Motor Disassembly and Reassembly
Industrial Ebikes
17万次观看 · 4年前

Brushless DC Motor, How it works ?
Lesics

http://v.youku.com/v_show/id_XODI1NTAyOTIw.html

Passcode: QSMotor

视频: How to Change Hall Sensor-QsMotor

YOUKU 优酷

03:32 / 21:01

标清

Replace the electric bearing:

1). **Instrument:** Pressure bearing tooling, press Or hammer.

2). **Material:** Bearing

3). **Operation method:**

- ①. According to the Motor disassemble method Previous Page expressed, disassemble the Motor.
- ②. Turn the Motor cover respectively by hands, confirm the damage bearing (Undamaged bearing shouldn't have abnormal sound).
- ③. Take out the Motor bearing from the bearing chamber.
- ④. Clean up the bearing chamber, then push the new bearing to bearing chamber. (As picture 9.7 showed)
- ⑤. After pushing, turn the Motor cover, check the replace bearing, confirm weather the bearing is install in-position and has abnormal sound).
- ⑥. Picture 9.8 is Motor bearing pressure equipment installation diagram.

4). **Precautions:**

- ①. Bearing pressure equipment most need frock press bearing outer race, Picture 9.7 Frock 1
- ②. Bearing pressure equipment process should improve bearing chamber vertical with bearing. Can't be incline, Picture 9.7 frock 2 is guiding shaft.
- ③. Before frock the bearing need to check the frock surface and bearing chamber clean.

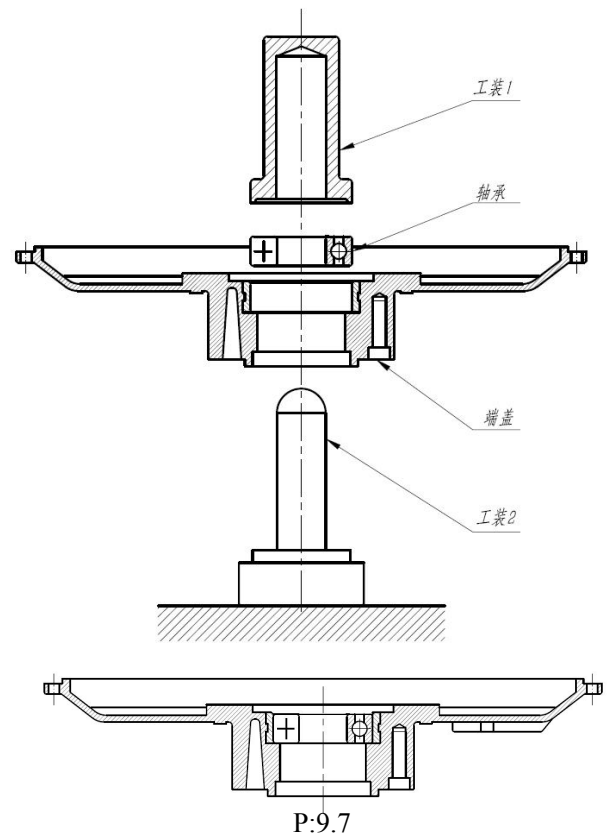

Rust

For rust motor, if rust lightly, the rotor, stator could be cleared by Iron sand, use gold lacquer on surface of the stator and rotor before assembly.

If rust serious, magnet could still work normally, it could be cleared by iron sand, use gold lacquer on surface of magnet. The stator couldn't get repaired, QS could offer new stator for replacement.

Burnt

Please send us some picture of the burnt stator.

If it caused by abuse usage of motor, it's not under warranty, we suggest to choose more powerful motors.

If it caused by motor quality, we could offer the stator and accessories for maintenance.

That's all, thank you!